

Features

- Transceiver unit with independent
 - 1310nm DFB Laser diode transmitter
 - APD receiver
- Meet SFF MSA with duplex LC receptacle
- Metal enclosure for lower EMI
- +3.3V Single power supply
- Qualified to meet the intent of Bellcore reliability practices
- LVPECL logic interface simplifiers interface to external circuitry
- LVTTTL logic signal detect output
- Links of 40km with 9/125 μm signal mode fiber (SMF)

Application

- SONET/SDH
- ATM

General

The optical transceiver is a high performance, cost effective module for serial optical data communication application.

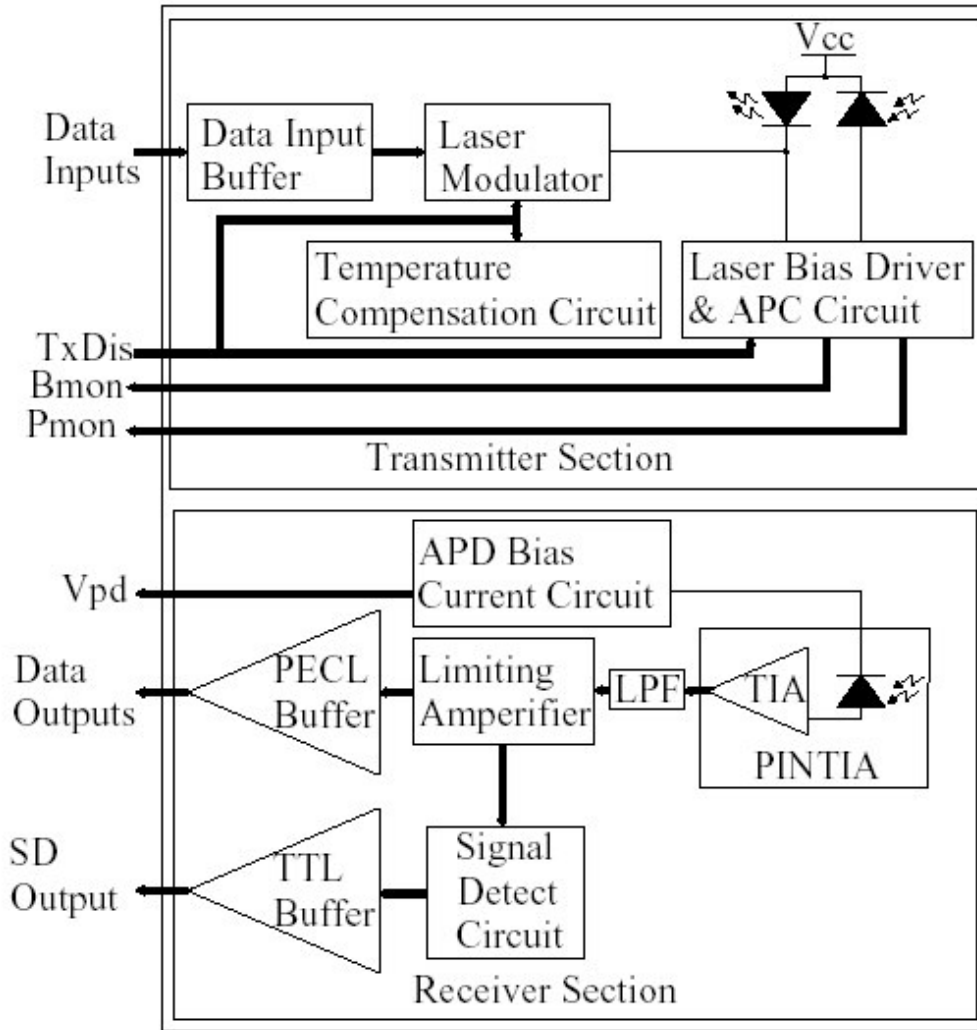

Transmitter Section

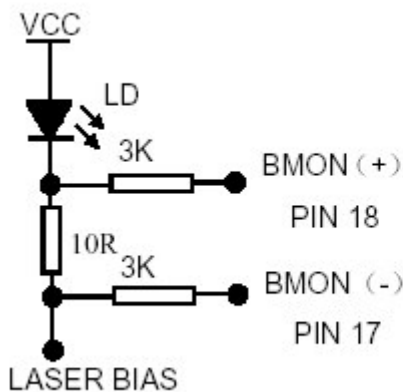

Figure2 LD Bias Current Monitor Circuit

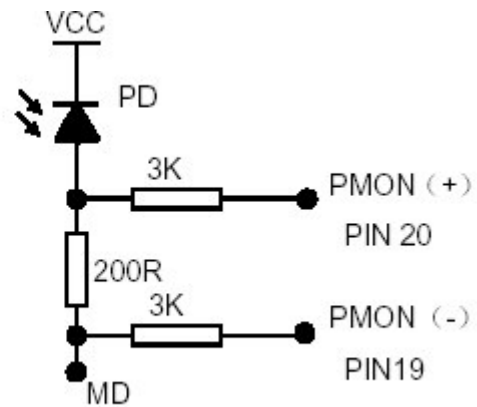

Figure 3 Power Monitor Circuit

Transmitter is designed for single mode fiber and operates at a nominal wavelength of 1310nm. The transmitter module uses a DFB laser diode and full IEC 825 and CDRH class 1 eye safety. The output optical power can be disabled via the single TxDis pin. Logic LVTTTL HIGH level disables the transmitter. It contains APC function, temperature compensation circuit, PECL data TxDis input interface, LD bias

current monitor circuit, power monitor circuit.

Receiver Section

The receiver section uses a hermetic packaged APD and a limiting amplifier. Which transforms input optical power to optical current through APD. And the optical current is transformed to voltage signal by trans-impedance amplifier. Differential DATA and /DATA LVPECL data signal is produced by limiting amplifier and voltage signal that is through limiting amplifier and filter. The receiver signal detect monitors input optical signal. When the optical power is not enough to support module operating normally, SD pin will beat LVTTTL logic level 0 and signal detect appears. The PINTIA is ac coupled to limiting amplifier through a low pass filter. The LPF are enough to pass the signal from 5Mb/s to 2600Mb/s without significant distortion or performance penalty.

Power Supply Filtering and Ground Planes

It is important to exercise care in circuit board layout to achieve optimum performance from these transceivers. It is further recommended that a continuous ground plane be provided in the circuit board directly under the transceiver to provide a low inductance ground for signal return current.

Electromagnetic Interference (EMI)

One of a circuit board designer's foremost concerns is the control of electromagnetic equipment. Success in controlling generated Electromagnetic Interference (EMI) enables the designer to pass a governmental agency's EMI regulatory standard and more importantly, it reduces the possibility of interference to neighboring equipment. The optical transceiver provides excellent EMI performance. The LC transceiver use forward and backward shields, which obturates the interstice of LC module effectually, and improves EMI performance.

Application note

There are a few fundamental guidelines to follow when designing the transceiver circuit interface. On the board, every data connection should be an impedance match. The data inputs and outputs lines should be treaded as 50 ohm micro strip line, and vias should be avoided. The matching resistor should be placed at the end of each matched line. The optical transceiver is high frequency, high bandwidth circuits. To ensure stability, use good high frequency layout techniques, filter voltage circuit, and keep ground connections short.

Cleaning Recommendations: The transceivers are supplied with a process plug to prevent contamination of the optical ports during shipping, handling and storage. So it is not need to clean it. In the event of contamination of the optical ports, the recommended cleaning process is the use of forced nitrogen. If contamination is thought to have remained, the optical ports can be cleaned using cotton sticker.

Performance Specifications

Table1. Absolute Maximum Ratings

Parameter	Symbol	Min	Max	Unit
Storage Temperature	Tst	-40	+85	°C
Input Voltage	-	GND	Vcc	V
Power Supply Voltage	Vcc-Vee	0	+3.6	V
Lead Soldering Temperature/Time	-	-	260/10	°C/S
Operating Temperature	To	0	+70	°C

Note: Stress in excess of maximum absolute ratings can cause permanent damage to the module

Tabel 2. Operating Environment

Parameter	Symbol	Min	Max	Unit
Power Supply Voltage	Vcc	+3.1	+3.5	V
Ambient Operating Temperature	Tc	0	+70	°C

Table 3. Optical and Electrical Characteristics

Parameter	Symbol	Min	Typ	Max	Unit	Note
Transmitter						
Center Wavelength	λ_p	1280	1310	1335	nm	
Spectral Width	$\Delta\lambda$	-	-	1.0	nm	
Side Mode Suppression Ratio	SMRS	30	-	-	dB	
Average Optical Output Power	Po	-2	-	+3	dBm	
Extinction Ratio	EXT	8.2	-	-	dB	
Transmitter disable Voltage	V _D	2.0	-	V _{CC}	V	
Transmitter Enable Voltage	V _{EN}	0	-	0.8	V	
Power Supply Current	I _{CC}	-	70	180	mA	1
Input Signal Amplitude	V _{pp}	300	800	2000	mV	
Laser Bias Monitor (Bmon(+)-Bmon(-))	-	-	0.05	0.9	V	
Power Monitor (Pmon(+)-Pmon(-))	-	0.01	0.1	0.2	V	
Output Eye	Compliant with ITU recommendation G957					
Receiver Specifications						
Parameter	Symbol	Min	Typ	Max	Unit	Note
Operate wavelength	λ	1260		1580	nm	
Sensitivity	P _r	-	-30	-27	dBm	2
Maximum input power	P _s	-9	-	-	dBm	2
Signal Detect Assert Level	-	-	-	-27	dBm	Low Level : Alarm
Signal Detect Deassert Level	-	-45	-	-	dBm	
Signal Detect Hysteresis		-	1.5	-	dB	
Power Supply Current	I _{CC}	-	110	220	mA	1
Output Data Amplitude	V _{pp}	400	500	2000	mV	
Receiver Optical Return Loss	-	-	-	-27	dB	
SD LOW- level voltage	V _{Lout}	-	-	0.8	V	
SD HIGH-level output voltage	V _{Hout}	2.0	-	-	V	

Note :

1. The current excludes the output load current.
2. Minimum sensitivity and saturation levels for a $2^{23} - 1$ PRBS with 72 ones and 72 zeros inserted (ITU recommendation G958)
3. RL=50R connected to a level of V_{CC} -2V.

Pin Definitions

Pin Out Diagram

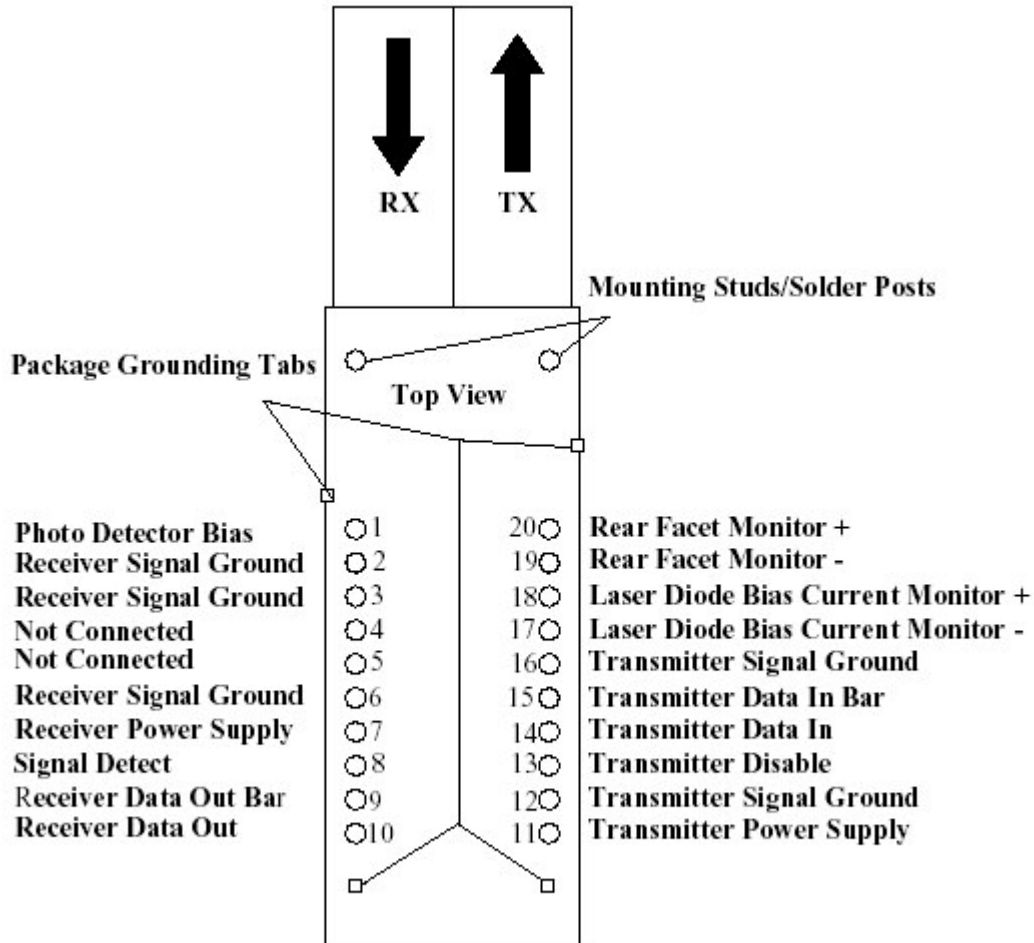

Pin Description

Pin#	Name	Function	Note
		Mounting Studs/Solder Poster	Note 1
		Package Grounding Tabs	Note 2
1	Vpd	Photon detector Bias	Note 3
2	VEER	Receiver Signal Grounding	Note 4
3	VEER	Receiver Signal Grounding	Note 4
4	NC	Not Connected	
5	NC	Not Connected	
6	VEER	Receiver Signal Grounding	Note 4
7	VCCR	Receiver Power Supply	Note 5
8	SD	Signal Detect	Note 6
9	RD-	Receiver Data Out Bar	Note 7
10	RD+	Receiver Data Out	Note 7
11	VCCT	Transmitter Power Supply	Note 8
12	VEET	Transmitter Signal Ground	Note 9
13	TxDis	Transmitter Disable	Note 10
14	TD+	Transmitter Data In	Note 11
15	TD-	Transmitter Data In Bar	Note 11
16	VEET	Transmitter Signal Ground	Note 9
17	BMON-	Laser Diode Bias Current Monitor-	Note 12
18	BMON+	Laser Diode Bias Current Monitor+	Note 12
19	PMON-	Rear Facet Monitor-	Note 13
20	PMON+	Rear Facet Monitor+	Note 13

Note:

1. The two mounting studs did not be connected to the interior of ground. They are provided for transceiver mechanical attachment to the circuit board. It is recommended that the holes in the circuit board be connected to chassis ground.
2. Those Tabs did not be connected to the interior of ground. Connect four package grounding tabs to receiver signal ground.
3. This pin enables monitoring of photo detector bias current. The pin should either be connected directly to VCCR_X, or to VCCR_X through a resistor for monitoring photo detector bias current.
4. Directly connect these pins to the receiver ground plane.
5. Provide +3.3 V dc via the recommended receiver power supply filter circuit. Locate the power supply filter circuit as close as possible to the VCC RX pin.
6. Normal optical input levels to the receiver result in a logic "1" output. Low optical input levels to the receiver result in a logic "0" output.
7. These are the differential receiver outputs. They are AC coupled 100 Ω differential lines which should be terminated with 100 Ω (differential) at the user SERDES. The AC coupling is done inside the module and is thus not required on the host board.
8. Provide +3.3V DC via the recommended transmitter power supply filter circuit. Locate the power supply filter circuit as close as possible to the VCC TX pin.
9. Directly connect these pins to the transmitter signal ground plane.
10. LVTTL logic lever, to enable module connect to TTL logic low "0".
11. These are the differential transmitter inputs. They are AC-coupled, differential lines with 100 Ω differential termination inside the module. The AC coupling is done inside the module and is thus not required on the host board.
12. The laser diode bias current is accessible by measuring the voltage developed across pins 17 and 18.
13. The rear facet monitor is accessible by measuring the voltage developed across pins 19 and 20.

Package Information

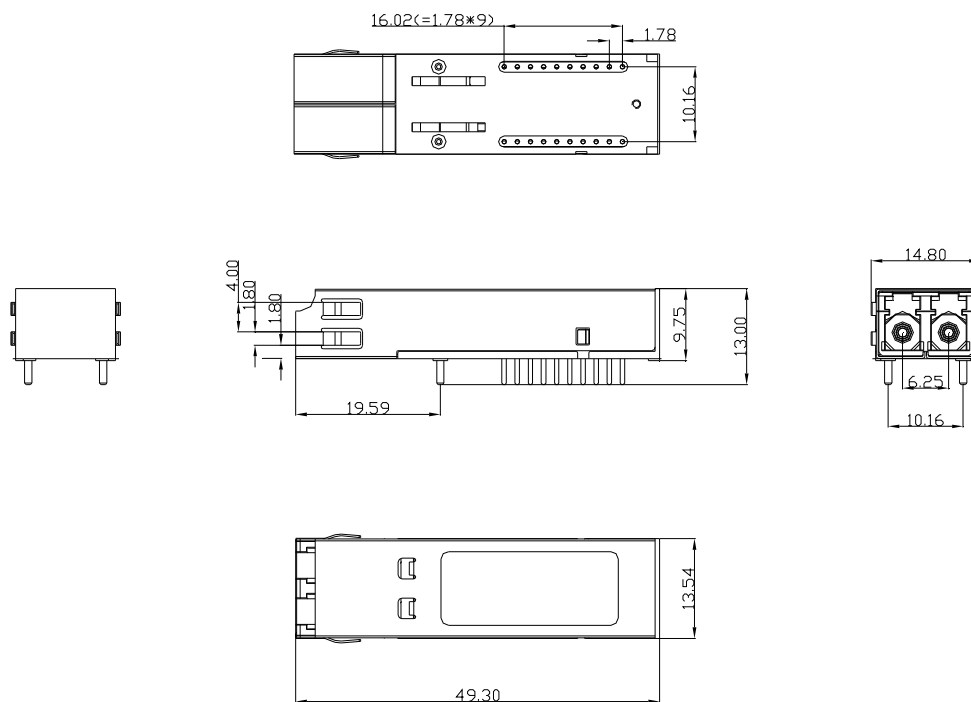

Recommended Circuit

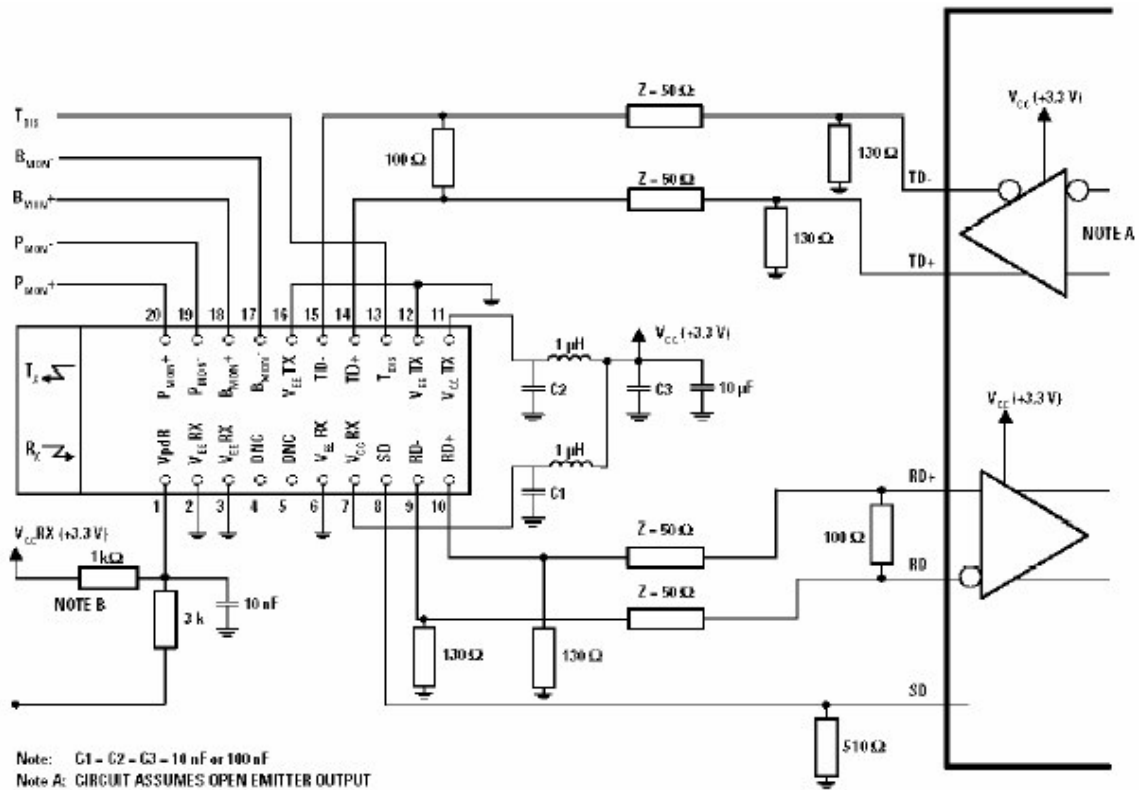

Recommended Board Layout Hole Pattern

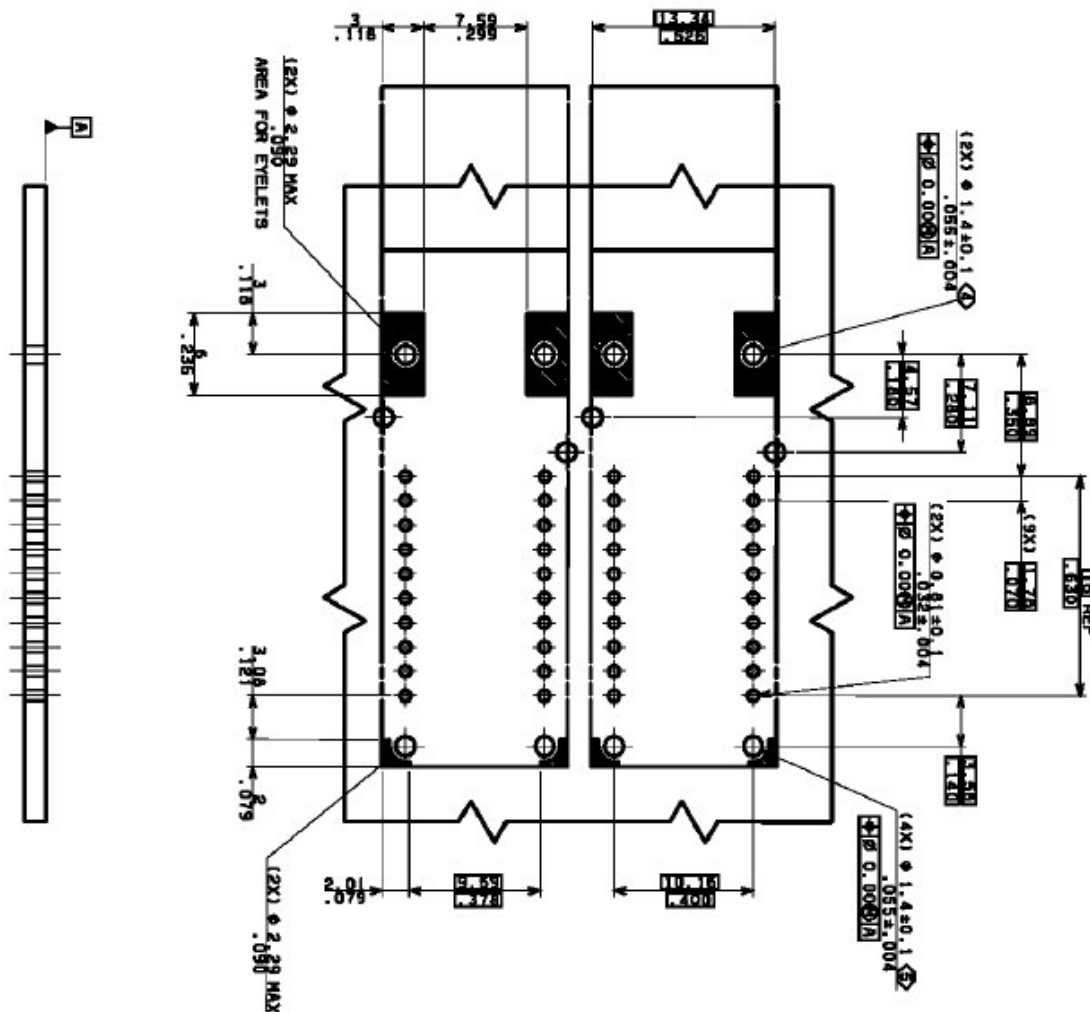

Obtaining Document

Please visit our website:

[Http://www.staropto.com](http://www.staropto.com)

Copyright Star Opto Co., Ltd. 2005

All Rights Reserved.

All information contained in this document is subject to change without notice. The products described in this document are NOT intended for use in implantation or other life support applications where malfunction may result in injury or death to persons.

The information contained in this document dose not affect or change Star’s product specifications or warranties. Nothing in this document shall operate as an express or implied license or indemnity under the intellectual property rights of Star or third parties. All information contained in this document was obtained in the specific environments, and is presented as an illustration. The results obtained in other operating environment may vary.

THE INFORMATION CONTAINED IN THIS DOCUMENT IS PROVIDED ON AN “AS IS” BASIS. In no event will Star be liable for the damages arising directly from any use of the information contained in this document.

Ordering Information

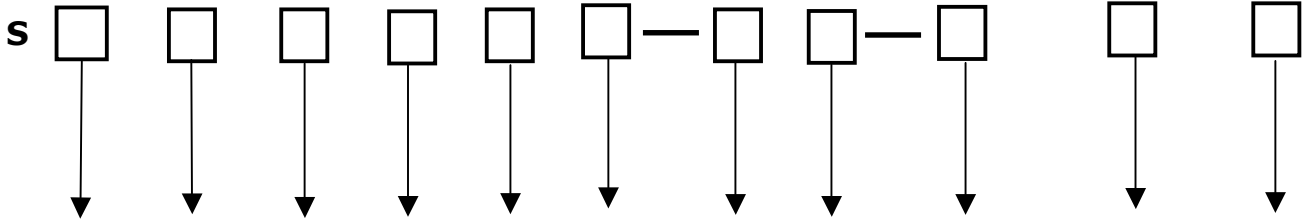

Classification:	Wavelength:	LD Type:	Data	Pack	Output	Power:	Operate	Signal	Optical
C: CWDM	3:1310 nm	1: FP	rate :	1:1*9(TR)	Power:	3:3.3V	Temperature:	Detect:	Interface
W: BIDI	5:1550nm	2:DFB	1:Ulrr	2:2*9(TR)	Show in	5:5V	1: 0~70℃	P: PECL	type:
	8:850nm	3:VCSEL	Low	1:2*5(FF)	the		2:-45~+85℃	T: TTL	1:FC/PC
	...Client	4:LED	2:52M	2:2*10(FF	Table 7				2:FC/APC
	Especial		3:155M)						3:SC/PC
	Requirement		4:633M						4:SC/APC
	.		5:1.25G						5:LC/PC
			6:2.5G						6:ST

Code	1	2	3	4	Unit
Power range					
Specification					
***-3*-	-15~-8	-5~0	-	0~5	dBm
***-4*-	-15~-8	-3~+2	-	1~5	
***-5*-	-10~-3	-3~+2	0~5	-	
***-6*-	-10~-3	-5~0	-2~+3	-	